



JCS JEIL E&S CO., LTD. | www.jeilens.co.kr
E-mail : jeil@jeilens.co.kr



본사

경남 양산시 유산동 39-5 Tel 055-383-1301 Fax 055-383-0853

화성 공장

경기도 화성시 마도면 쌍송리 667-6 마도산업단지 3B 3L
Tel 031-357-6751~3 Fax 031-357-6754

서울사무소

서울특별시 송파구 방이동 186 Tel 02-413-6090~2 Fax 02-413-6493~4

여수사무소

전남 여수시 신기동 92-7 Tel 061-685-1150 Fax 061-685-1151

청도공장

청도 교남시 해빈공업원 (청도 제일 밀봉 제품 유한 공사)
青岛 胶南市 海滨工业园 (青岛第逸密封制品有限公司)
Tel 86-532-8513-6021 Fax 86-532-8513-6020

HEAD OFFICE & FACTORY

39-5, Yusan-Dong, Yangsan-City, Kyungnam, Korea
Tel 82-55-383-1301 Fax 82-55-383-0853

HWASEONG OFFICE & FACTORY

(3B 3L Mado IND.Complex) 667-6, Ssangsong-Ri, Mado-Myun,
Hwaseong-City, Kyunggi-Do, Korea
Tel 82-31-357-6751~3 Fax 82-31-357-6754

SEOUL OFFICE

186, Bangyee-Dong, Songpa-Gu, Seoul, Korea
Tel 82-2-413-6090~2 Fax 82-2-413-6493~4

YEOSOO OFFICE

92-7, Shingi-Dong, Yeosoo-City, Cheonnam, Korea
Tel 82-61-685-1150 Fax 82-61-685-1151

QINGDAO OFFICE & FACTORY CHINA

Haibin Factory Complex, Jiaonan-City, Qingdao, China
Tel 86-532-8513-6021 Fax 86-532-8513-6020

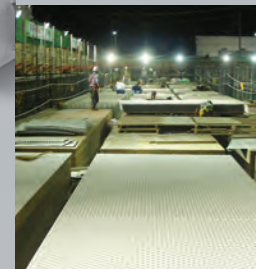

STARFLON® Lined & Coated Products
Semiconductor Related Products
Plant Engineering & Construction
Pollution Control Facilities
HVAC Products



CONTACT

Value Creation for Customers!

Jeil who has constantly pursued technology development and customer satisfaction since the foundation of the company is now aiming for a globalized enterprise to fit with the rapidly changing industrial environments through the ceaseless technology advancement.

Jeil will do its utmost efforts to maintain the world best quality by the reinforced QC system and the continued product development which will redound to the benefits of our society and country as well as customers.



JEIL E&S Global Network

A giant leap for future and environment beyond 40 years of tradition!

Do better tomorrow with excellent human resources and state-of-the-art-technologies.

It's Creative Technology! JEIL E&S

History

- Oct. 1969 Founded "Jeil Chemical Industry Co."
- Jun. 1971 Founded "Jeil Asbestos Co.,Ltd." under the Joint Venture With Nippon Asbestos Co.,Ltd.
- Oct. 1978 Started the production of Spiral Wound Gaskets under the Technical Transfer Agreement with Nichias(Japan).
- Sep. 1984 Started the production of Metal Jacket Gaskets under the Technical Transfer Agreement with Nichias(Japan).
- Mar. 1985 Selected as "An Excellent Labor-Management Company" with the Presidential Award.
- Dec. 1985 Acquired the using right of KS(Korean Standard) on Compressed Asbestos Sheet.
- Dec. 1985 Firstly developed asbestos free gasket sheet in Korea.
- Nov. 1987 Got " the Order of Industrial Service Merit" from the President.
- Apr. 1990 Started the PTFE business under the Technical Transfer Agreement with Nippon Valqua(Japan).
- Jun. 1990 Transferred Asbestos Textile Manufacturing Equipment to Indonesia (PT.Tri-Graha Sealisindo).
- Jan. 1992 Approved as a "Q" grade supplier to Youngkwang Nuclear Power Plant (Gasket).
- Jan. 1993 Approved as "A" grade supplier to Hyundai Heavy Industries(Gasket).
- Nov. 1993 Approved as an official supplier to Wolsung Nuclear Power Plant III&IV (Spiral Wound Gasket).
- Jul. 1994 Licensed the right to use API Monogram (Ring Joint Gasket: 6A-0372)
- Jun. 1995 Approved as an official supplier to Ulijn Nuclear Power Plant III&IV (Packing & Gasket).
- Aug. 1995 Acquired ISO 9002 Certificate (Intertek/USA)
- Sep. 1995 Founded the company Technical Research Institute.
- Jan. 1996 Firstly developed Cryogenic Spiral Wound gasket in Korea (Approved by "Korea Research Institute of Standard and Sciences")
- May. 1997 Got the formal approval on Cryogenic Spiral Wound gasket from KR ("Korean Register of Shipping" : BSN 02539-GT002)
- Jun. 1998 Acquired "Seoul Chemplant Co.,Ltd." (STARFLON Coating & Lining)
- Sep. 1998 Got the formal approval on Cryogenic Spiral Wound Gasket from Det Norske Veritas" (certificate No.P-10159, Rev.1).
- Dec. 1999 Acquired "UN" Mark on Vessel and Drum.
- Jan. 2000 Changed the name of company to " Jeil E&S Co.,Ltd." engineering sealing
- Sep. 2001 Acquired ISO 9001 Certificate (KSA)
- Apr. 2003 Established a "Qingdao Jeil sealing Co.,Ltd. in China.
- Sep. 2003 Participated cleaner production spread project(SK-SCEM).
- Mar. 2006 Moved to a larger facility located in Hwaseong City from Kimpo City.
- Jul. 2006 Assigned partner company with KITECH.
- Aug. 2007 Registered on Aramco(Aramco Overseas company BV).
- Nov. 2007 Developed "STARPITE(Spiral wound gasket filler)" for high temperature.
- Jun. 2009 Developed "JIC 6400(compress sheet for high temperature)."
- Oct. 2009 Acquired ISO 9001/14001 Certificate.
- Feb. 2010 Acquired "Lloyd's Register of Shipping" Certificate (Compress Sheet)
- May.2011 Acquired Achilles JQS Certificate (ID: 28492)
- Apr. 2012 Acquired API Monogram Certificate.

Head Office (Kyungnam)



Seoul Office



Hwaseong Office & Factory



Qingdao Office & Factory China



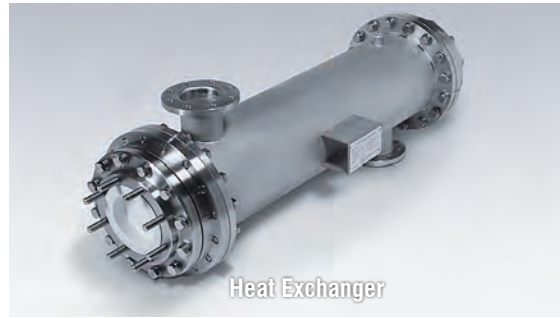

Heat Exchanger



Tank Lining



Semiconductor Related Products



Semiconductor Related Product



STARFLON® Lined Products



Tank Lorry



Plant Construction



HVAC Products



WWT, DI, UPW System



Pollution Control Facilities

STARFLON® Lined & Coated Products 06

- Pipe & Fittings
- Tank & Vessel Lining
- STARFLON® Coating & Special Coating

Semiconductor Related Products 13

- Semiconductor Related Products
- PFA Lined Ball Valve
- PFA Lined Diaphragm Valve
- PFA Lined Ball Check Valve
- Tank Lorry & ISO Container
- Others Products

Plant Engineering & Construction 19

- Plant Engineering
- Plant Construction

Pollution Control Facilities 21

- Scrubber, Tank, Piping
- WWT, DI, UPW System
- C.P.L.(Concrete Protect Lining)

HVAC Products (Heating, Ventilation, Air Conditioning) 23

- HVAC Construction
- HVAC Unit

Appendix 25

- Comparison between Plastic and Metal
- Chemical Resistance Chart

Gasket & Packing 27



STARFLON® Lined & Coated Products



STARFLON® Lined & Coated Products

Pipe & Fitting

Jeil has its own unique and advanced technology of lining process. According to complicated demands and application conditions of customers, Jeil can design and manufacture a variety of products with a wide range of material from fluoropolymer to thermoplastic material.

Especially, the superior heat-resistant and chemical-resistant fluoropolymer linings (PTFE, PFA, etc.) are provided to the customers with a highly efficient combination of advanced technical lining know-how.

Material

- Housing**
Carbon Steel / SUS 304
- Liner**
PTFE / PFA / PVDF / PP

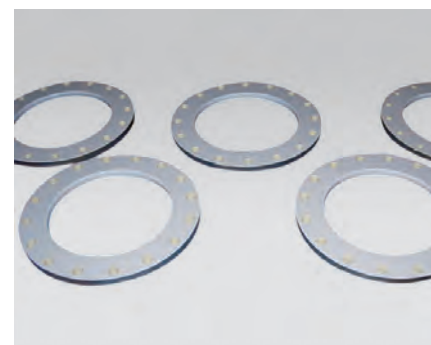

Pipe

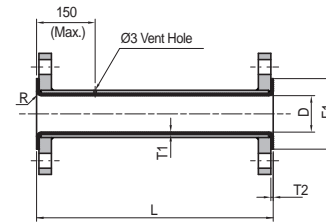

ANSI 150#

Unit: mm

Size	L		D	F1 (Min.)	T1 (Min.)	T2 (Min.)	Ring Plate		Weight(kg)	
	Max.	Min.					F2	T3	FLG.x 2Ea	Pipe x0.1M
1/2	3000	75	14.9	31.8	3	2.5	43	5	1.15	0.21
3/4	3000	80	14.9	39.7	3	2.5	53	5	1.48	0.21
1	3000	85	20.6	47.6	3	2.5	62	5	2.28	0.31
1-1/2	3000	90	34.9	68.3	3	2.5	81	5	3.16	0.49
2	3000	105	46.5	87.3	3	2.5	99	5	3.81	0.65
2-1/2	3000	115	56.7	106.7	3	2.5	118	7	5.28	1.04
3	3000	115	71.9	117.5	3	2.5	131	7	5.31	1.29
4	3000	115	96.3	150.8	3	2.5	169	8	6.44	1.88
5	3000	120	118.2	179.5	5	4.5	190	8	9.83	2.60
6	3000	130	144.1	203.2	5	4.5	216	8	13.06	3.28
8	3000	140	192.7	255.6	5	4.5	273	10	15.57	4.89
10	3000	150	244.5	311.2	5	4.5	332	10	26.14	6.77
12	2000	170	293.2	365.1	5	4.5	402	12	28.44	8.85
14	2000	180	323.3	393.7	5	4.5	443	12	37.45	10.57
16	2000	190	371.0	450.9	5	4.5	506	14	51.79	13.61

1.①PTFE LINING ②FLANGE ANSI150# A105, A182.F304 SO FF ③PIPE A53 GR.B, A312.TP304, 1/2"-16": SCH.40, 20, 10 ④RING PLATE SS400, SUS304 ⑤VENT HOLE 1) LENGTH 1000mm ↓ 1 POINT 2) LENGTH 1000mm ↑ 2 POINT (0°,180°)
2.FLANGE FIXED TYPE (Jeil STANDARD) 3.ROUND 1/2"-4": R3, 5"-16": R5
4.WELDING GTAW + FCAW, GTAW, FCAW, SMAW, GTAW + SMAW 5.PP, PVDF-PLEASE CONTACT SALES DEPARTMENT.

Elbow 90°, 45°

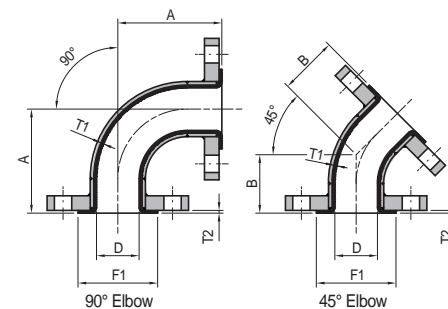

ANSI 150#

Unit: mm

Size	A (90°)	B (45°)	D	F1 (Min.)	T1 (Min.)	T2 (Min.)	Ring Plate		Weight(kg)	
							F2	T3	90°	45°
1/2	70	45	14.9	31.8	3	2.5	43	5	1.49	1.21
3/4	80	45	14.9	39.7	3	2.5	53	5	1.82	1.63
1	89	58	20.6	47.6	3	2.5	62	5	2.84	2.50
1-1/2	102	58	34.9	68.3	3	2.5	81	5	4.16	3.73
2	114	64	46.5	87.3	3	2.5	99	5	5.29	4.64
2-1/2	130	76	56.7	106.7	3	2.5	118	7	7.93	6.86
3	140	76	71.9	117.5	3	2.5	131	7	8.91	7.27
4	165	102	96.3	150.8	3	2.5	169	8	12.64	10.27
5	194	114	118.2	179.5	4.5	4.5	190	8	19.92	15.76
6	203	127	144.1	203.2	4.5	4.5	216	8	26.39	21.40
8	228	140	192.7	255.6	4.5	4.5	273	10	37.88	28.39
10	280	165	244.5	311.2	4.5	4.5	332	10	64.07	48.09
12	305	191	293.2	365.1	4.5	4.5	402	12	90.40	62.78
14	356	191	323.3	393.7	4.5	4.5	443	12	124.16	85.03
16	381	203	371.0	450.9	4.5	4.5	506	14	158.56	121.46

1.①PTFE LINING ②FLANGE ANSI150# A105, A182.F304 SO FF ③90° ELBOW / 45° ELBOW A234-WPB, A403.WP304,1/2"-16": SCH.40, 20, 10 ④RING PLATE SS400, SUS304 2.90° ELL 1/2"-3": Long Type, 4"-14:Short Type, 45° ELL All: Long Type
3.FLANGE FIXED TYPE (JEILSTANDARD) 4.ROUND 1/2"-4": R3, 5"-16": R5
5.WELDING GTAW + FCAW, GTAW, FCAW, SMAW GTAW + SMAW 6.PP, PVDF-PLEASE CONTACT SALES DEPARTMENT.

STARFLON® Lined & Coated Products

STARFLON® Lined & Coated Products

Straight / Cross Tee

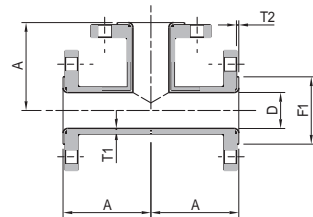

ANSI 150#

Unit:mm

Size	A	D	F1 (Min.)	T1 (Min.)	T2 (Min.)	Ring Plate		Weight(kg)	
						F2	T3	Tee	Cross
1/2	70	14.9	31.8	3	3	43	5	2.33	2.09
3/4	80	14.9	39.7	3	3	53	5	2.73	3.64
1	89	20.6	47.6	3	3	62	5	4.25	5.67
1-1/2	102	34.9	68.3	3	3	81	5	6.24	8.32
2	114	46.5	87.3	3	3	99	5	7.94	10.59
2-1/2	130	56.7	106.7	3	3	118	7	11.89	15.86
3	140	71.9	117.5	3	3	131	7	13.37	17.83
4	165	96.3	150.8	3	3	169	8	18.96	25.27
5	194	118.2	179.5	4.5	4.5	190	8	29.88	39.84
6	203	144.1	203.2	4.5	4.5	216	8	39.59	52.78
8	228	192.7	255.6	4.5	4.5	273	10	56.82	75.76
10	280	244.5	311.2	4.5	4.5	332	10	96.10	128.14
12	305	293.2	365.1	4.5	4.5	402	12	123.65	164.87
14	356	323.3	393.7	4.5	4.5	443	12	169.14	225.48
16	381	371.0	450.9	4.5	4.5	506	14	181.42	241.89

1.①PTFE LINING ②FLANGE ANSI150# A105, A182.F304 SO FF ③TEE/CROSS A234-WPB, A403.WP304, 1/2"-16": SCH.40, 20, 10 ④RING PLATE SS400, SUS304 2.FLANGE FIXED TYPE (JEIL STANDARD) 3.ROUND 1/2"-4": R3 / 5"-16": R5
4.WELDING GTAW + FCAW, GTAW, FCAW, SMAW, GTAW + SMAW 5.PP, PVDF-PLEASE CONTACT SALES DEPARTMENT.

Reducing Tee

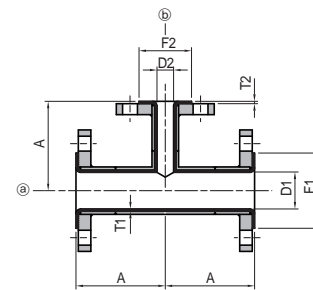

ANSI 150#

Unit:mm

Size		A	D1	D2	F1 (Min.)	F2 (Min.)	T1 (Min.)	T2 (Min.)	Ring Plate			Weight (kg)
①	②								F3 ③	F3 ④	T3	
1	3/4	89	20.6	14.9	47.6	39.7	3	3	62	53	5	3.76
1-1/2	3/4	102	34.9	14.9	68.3	39.7	3	3	81	53	5	5.12
1-1/2	1	102	34.9	20.6	68.3	47.6	3	3	81	62	5	6.60
2	3/4	114	46.5	14.9	87.3	39.7	3	3	99	53	5	6.28
2	1	114	46.5	20.6	87.3	47.6	3	3	99	62	5	6.79
2	1-1/2	114	46.5	34.9	87.3	68.3	3	3	99	81	5	7.43
2-1/2	1	127	56.7	20.6	106.7	47.6	3	3	118	62	7	9.46
2-1/2	1-1/2	127	56.7	34.9	106.7	68.3	3	3	118	81	7	10.13
2-1/2	2	127	56.7	46.5	106.7	87.3	3	3	118	99	7	10.66
** 3	1	140	71.9	20.6	117.5	47.6	3	3	131	62	7	10.49
3	1-1/2	140	71.9	34.9	117.5	68.3	3	3	131	81	7	11.18
3	2	140	71.9	46.5	117.5	87.3	3	3	131	99	7	11.73
3	2-1/2	140	71.9	56.7	117.5	106.7	3	3	131	118	7	13.01
** 4	1	165	96.3	20.6	150.8	47.6	3	3	169	62	8	13.89
4	1-1/2	165	96.3	34.9	150.8	68.3	3	3	169	81	8	15.03
4	2	165	96.3	46.5	150.8	87.3	3	3	169	99	8	15.61
4	2-1/2	165	96.3	56.7	150.8	106.7	3	3	169	118	8	17.00
4	3	165	96.3	71.9	150.8	117.5	3	3	169	131	8	17.42
5	2	194	118.2	46.5	179.5	87.3	3	3	190	99	8	23.09
5	2-1/2	194	118.2	56.7	179.5	106.7	3	3	190	118	8	24.58
5	3	194	118.2	71.9	179.5	117.5	3	3	190	131	8	25.07
5	4	194	118.2	96.3	179.5	150.8	4.5	4.5	190	168	8	26.78
** 6	2	203	144.1	46.5	203.2	87.3	4.5	4.5	216	99	8	29.82
6	3	203	144.1	71.9	203.2	117.5	4.5	4.5	216	131	8	31.66
6	4	203	144.1	96.3	203.2	150.8	4.5	4.5	216	168	8	33.42
** 8	2	228	192.7	46.5	255.6	87.3	4.5	4.5	273	99	10	41.27
** 8	3	228	192.7	71.9	255.6	117.5	4.5	4.5	273	131	10	43.47
8	4	228	192.7	96.3	255.6	150.8	4.5	4.5	273	169	10	45.38
8	6	228	192.7	144.1	255.6	203.2	4.5	4.5	273	216	10	51.90
** 10	2	280	244.5	46.5	311.2	87.3	4.5	4.5	332	99	10	67.79
** 10	3	280	244.5	71.9	311.2	117.5	4.5	4.5	332	131	10	70.33
10	4	280	244.5	96.3	311.2	150.8	4.5	4.5	332	169	10	72.55
10	6	280	244.5	144.1	311.2	203.2	4.5	4.5	332	216	10	79.79
10	8	280	244.5	192.7	311.2	255.6	4.5	4.5	332	273	10	85.55
** 12	2	305	293.2	46.5	365.1	87.3	4.5	4.5	402	99	12	86.32
** 12	3	305	293.2	71.9	365.1	117.5	4.5	4.5	402	131	12	89.02
** 12	4	305	293.2	96.3	365.1	150.8	4.5	4.5	402	169	12	91.38
12	6	305	293.2	144.1	365.1	203.2	4.5	4.5	402	216	12	98.98
12	8	305	293.2	192.7	365.1	255.6	4.5	4.5	402	273	12	105.14
12	10	305	293.2	244.5	365.1	311.2	4.5	4.5	402	332	12	114.08
** 14	2	356	323.3	46.5	393.7	87.3	4.5	4.5	443	99	12	116.96
** 14	3	356	323.3	71.9	393.7	117.5	4.5	4.5	443	131	12	119.98
14	4	356	323.3	96.3	393.7	150.8	4.5	4.5	443	169	12	124.92
14	6	356	323.3	144.1	393.7	203.2	4.5	4.5	443	216	12	149.92
14	8	356	323.3	192.7	393.7	255.6	4.5	4.5	443	273	12	158.47
16	8	407	371.0	192.7	450.9	255.6	4.5	4.5	506	273	14	190.26
16	10	407	371.0	244.5	450.9	311.2	4.5	4.5	506	332	14	203.20
16	12	407	371.0	293.2	450.9	365.1	4.5	4.5	506	402	14	212.81
16	14	407	371.0	323.3	450.9	393.7	4.5	4.5	506	443	14	224.33

1.①PTFE LINING ②FLANGE ANSI150# A105, A182.F304 SO FF ③REDUCING TEE A234-WPB, A403.WP304, 3/4"-16": SCH.40, 20, 10 ④RING PLATE SS400, SUS304 2.**: Tee Non STANDARD 3.FLANGE FIXED TYPE (JEIL STANDARD)
4.ROUND 1/2"-4": R3, 5"-16": R5 5.WELDING GTAW + FCAW, GTAW, FCAW, SMAW, GTAW + SMAW
6.PP, PVDF-PLEASE CONTACT SALES DEPARTMENT.

STARFLON® Lined & Coated Products

STARFLON® Lined & Coated Products

Reducer

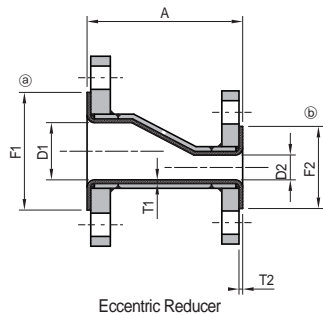
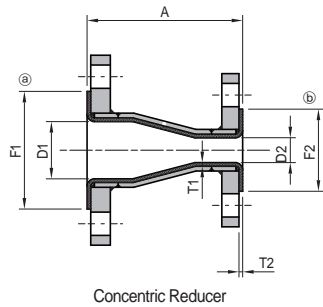

ANSI 150#

Unit : mm

Size		A	D1	D2	F1 (Min.)	F2 (Min.)	T1 (Min.)	T2 (Min.)	Ring Plate		Weight (kg)	
Ⓐ	Ⓑ								F3 Ⓐ	F3 Ⓑ		
1	3/4	100	20.6	14.9	47.6	39.7	3	3	62	53	4.02	
1-1/2	3/4	100	34.9	14.9	68.3	39.7	3	3	81	53	4.99	
1-1/2	1	100	34.9	20.6	68.3	47.6	3	3	81	62	5.84	
2	1	130	46.5	20.6	87.3	47.6	3	3	99	62	6.79	
2	1-1/2	130	46.5	34.9	87.3	68.3	3	3	99	81	7.70	
**2-1/2	1-1/2	130	56.7	34.9	106.7	68.3	3	3	118	81	9.41	
2-1/2	2	130	56.7	46.5	106.7	87.3	3	3	118	99	10.17	
3	1	152	71.9	20.6	117.5	47.6	3	3	131	62	8.81	
3	1-1/2	152	71.9	34.9	117.5	68.3	3	3	131	81	9.82	
3	2	152	71.9	46.5	117.5	87.3	3	3	131	99	10.59	
3	2-1/2	152	71.9	56.7	117.5	106.7	3	3	131	118	12.36	
(ECC)**	4	1-1/2	152	96.3	34.9	150.8	68.3	3	3	169	81	11.40
4	2	152	96.3	46.5	150.8	87.3	3	3	169	99	12.18	
**	4	2-1/2	152	96.3	56.7	150.8	106.7	3	3	169	118	13.94
4	3	152	96.3	71.9	150.8	117.5	3	3	169	131	14.16	
5	2	180	118.2	46.5	179.5	87.3	4.5	4.5	190	99	16.57	
5	2-1/2	180	118.2	56.7	179.5	106.7	4.5	4.5	190	118	18.39	
5	3	180	118.2	71.9	179.5	117.5	4.5	4.5	190	131	18.64	
5	4	180	118.2	96.3	179.5	150.8	4.5	4.5	190	169	20.30	
(CON)**	6	2	200	144.1	46.5	203.2	87.3	4.5	4.5	216	99	20.80
**	6	2-1/2	200	144.1	56.7	203.2	106.7	4.5	4.5	216	118	22.66
6	3	200	144.1	71.9	203.2	117.5	4.5	4.5	216	131	22.94	
6	4	200	144.1	96.3	203.2	150.8	4.5	4.5	216	169	24.66	
(CON)**	8	4	200	192.7	96.3	255.6	150.8	4.5	4.5	273	169	28.78
8	6	200	192.7	144.1	255.6	203.2	4.5	4.5	273	216	36.80	
(ECC)**	10	3	250	244.5	71.9	311.2	117.5	4.5	4.5	332	131	41.53
(CON)**	10	4	250	244.5	96.3	311.2	150.8	4.5	4.5	332	169	43.40
**	10	6	250	244.5	144.1	311.2	203.2	4.5	4.5	332	216	51.77
(ECC)**	10	8	250	244.5	192.7	311.2	255.6	4.5	4.5	332	273	56.29
(ECC)**	12	6	300	293.2	144.1	365.1	203.2	4.5	4.5	402	216	59.70
**	12	8	300	293.2	192.7	365.1	255.6	4.5	4.5	402	273	64.62
(ECC)**	12	10	300	293.2	244.5	365.1	311.2	4.5	4.5	402	332	78.02
(CON)**	14	6	350	323.3	144.1	393.7	203.2	4.5	4.5	443	216	74.76
**	14	8	350	323.3	192.7	393.7	255.6	4.5	4.5	443	273	80.08
**	14	10	350	323.3	244.5	393.7	311.2	4.5	4.5	443	332	93.95
**	14	12	350	323.3	293.2	393.7	365.1	4.5	4.5	443	402	99.88
16	10	400	371.0	244.5	450.9	311.2	4.5	4.5	506	332	118.69	
16	12	400	371.0	293.2	450.9	365.1	4.5	4.5	506	402	125.15	
16	14	400	371.0	323.3	450.9	393.7	4.5	4.5	506	443	137.60	

1. ⒶPTFE LINING ⒶFLANGE ANSI150# A105, A182.F304 SO FF
 ⒶCON. RED./ECC. RED A234-WPB, A403.WP304, 3/4"-16":SCH.40, 20, 10 ⒶRING PLATE SS400, SUS304
 2.** : Have No Mold 3.FLANGE FIXED TYPE (JEIL STANDARD)
 4.ROUND 1/2"-4":R3 / 5"-16":R5 5.WELDING GTAW + FCAW, GTAW, FCAW, SMAW / GTAW + SMAW
 6.PP, PVDF-PLEASE CONTACT SALES DEPARTMENT.

Tank & Vessel Lining

Material

Fluoropolymer (PTFE, PFA, FEP, PVDF, ECTFE)
 +SUS, FRP & Carbon Steel
 PP, HD-PE+Metal FRP
 PVC+FRP / PVE / FRP

Jeil's Tank Lining and Vessel Lining show the superior performance under the wide service range of temperature and pressure by the excellent heat-resistant and chemical resistant properties of fluoropolymer.

Accordingly, they are safely used for petro-chemical plants, chemical plants, pulp plants, metal plant, etc.

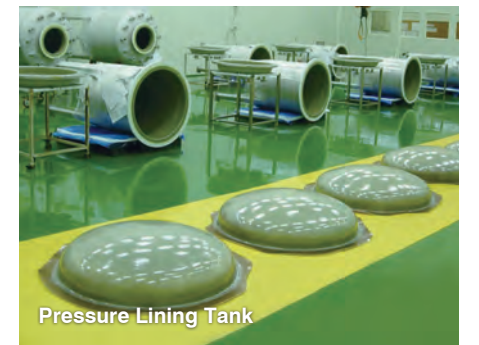
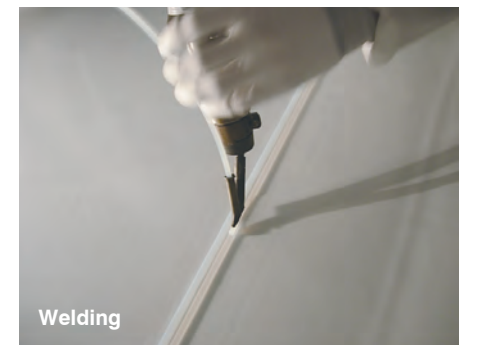
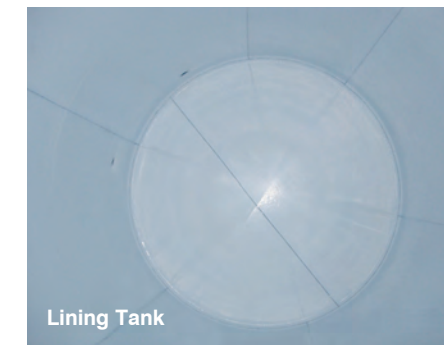



STARFLON® Lined & Coated Products

**STARFLON®
Coating & Special
Coating**

Material
(PFA, FEP, PVDF, ETFE, PTFE, JAP)
+Metal(Steel, Aluminum, SUS)
****JAP**
Special Coating

Jeil-aiming for more advanced technology and service is a forefront runner of Teflon coating field.

Teflon firstly developed by DuPont, USA in 1930's shows the superior performance in chemical resistance, nonadhesiveness and abrasive resistance.

Teflon coating easily available for aluminum, steel, stainless steel and other materials are widely used for almost overall industrial fields by application methods of spray, powder coating, etc.

Jeil technical department precisely performs a coating process with a combination of new material and new technology.



Auto Mixing Unit

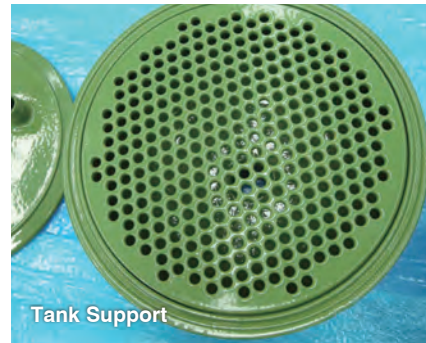

Tank Support

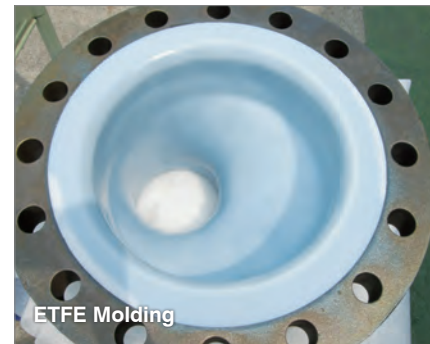

ETFE Molding

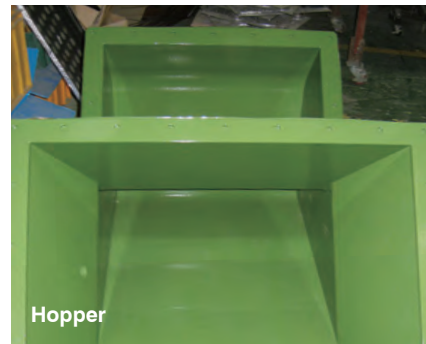

Hopper



Semiconductor Related Products

**Semiconductor
Related
Products**



Semiconductor Related Products

Semiconductor Related Products

PFA Lined Ball Valve

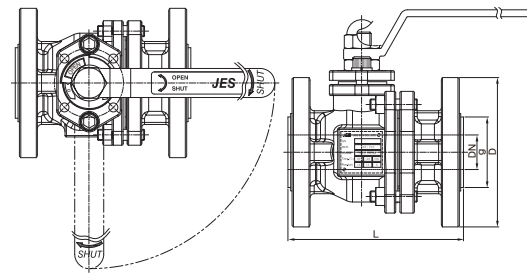

Dimensions

Unit: mm

Size	ød	øD		L		øg		Ref.
		ANSI 150	JIS 10K	ANSI 150	JIS 10K	ANSI 150	JIS 10K	
1/2(15A)	15	89	95	127	140	40	40	A
3/4(20A)	20	98.5	100	127	150	55	55	B
1(25A)	25	108	125	127	165	55	55	C
1-1/2(40A)	38	127	140	165	191	73	81	D
2(50A)	50	152	155	178	216	95	95	E
3(80A)	76	190.5	185	203	250	125	125	G
4(100A)	100	229	210	229	280	151	151	H
6(150A)	145	279.5	280	267	267	212	212	J

PFA Lined Diaphragm Valve

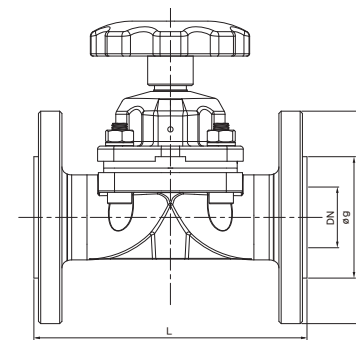

Diaphragm Valve

Unit: mm

Size	ød	øD		L	øg		øB	Max. Service Pressure (kgf/cm ²)	Ref.
		ANSI 150	JIS 10K		ANSI 150	JIS 10K			
1/2(15A)	15	89	95	133	40	55	ø75	8	A
3/4(20A)	20	98.5	100	133	47	55	ø75	8	B
1(25A)	25	108	125	143	60	60	ø90	8	C
1-1/2(40A)	38	127	140	180	73	73	ø105	7	D
2(50A)	50	152	155	210	90	90	ø115	7	E
3(80A)	76	190.5	185	310	125	125	ø210	6	G
4(100A)	101	229	210	350	157	151	ø210	6	H
6(150A)	150	279	280	480	216	216	ø350	6	J

Automated Ball Valve : Spring Return

Unit: mm

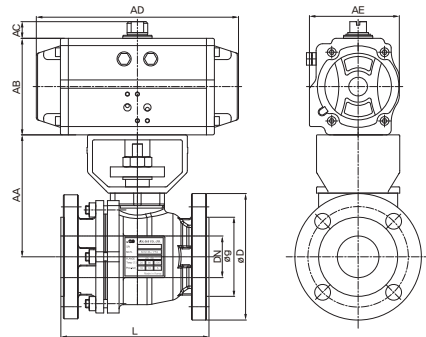

Size	AA	AB	AC	AD	AE	ød	øD		L		øg	
							ANSI 150	JIS 10K	ANSI 150	JIS 10K	ANSI 150	JIS 10K
1/2(15A)	109	104.7	20	161.2	83.7	15	89	95	127	140	40	40
3/4(20A)	109	104.7	20	161.2	83.7	20	98.5	100	127	150	55	55
1(25A)	109	104.7	20	161.2	83.7	25	108	125	127	150	55	55
1-1/2(40A)	123	136	20	243	108	38	127	140	165	165	73	81
2(50A)	146	136	20	243	108	50	152	155	178	210	95	95
3(80A)	205	148	20	266.2	122.5	76	190.5	185	203	250	125	125
4(100A)	215	189	30	348.5	151	96	229	210	229	280	151	151
6(150A)	281	226	30	449.4	202	145	279.5	280	267	267	212	212

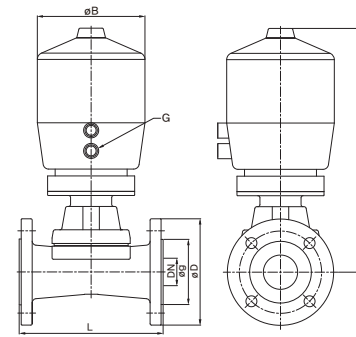

Automated Diaphragm Valve

Unit: mm

Size	ød	øD		L	øg		H	øB	Ref.
		ANSI 150	JIS 10K		ANSI 150	JIS 10K			
1/2(15A)	15	89	95	133	40	40	179	125	1/4"
3/4(20A)	20	98.5	100	133	55	55	179	125	1/4"
1(25A)	25	108	125	143	64	64	180	125	1/4"
1-1/2(40A)	38	127	140	180	73	80	230	155	1/4"
2(50A)	50	152	155	210	95	95	275	210	1/4"
3(80A)	76	190.5	185	310	125	125	410	258	1/4"
4(100A)	101	229	210	350	151	151	440	328	1/4"

Automated Ball Valve : Double Acting

Unit: mm

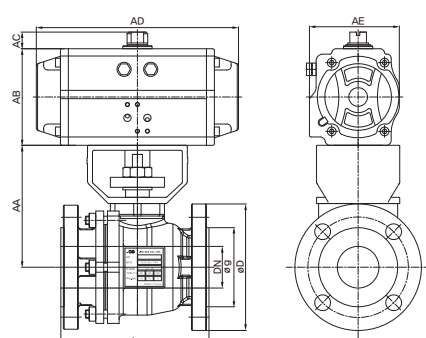

Size	AA	AB	AC	AD	AE	ød	øD		L		øg	
							ANSI 150	JIS 10K	ANSI 150	JIS 10K	ANSI 150	JIS 10K
1/2(15A)	109	104.7	20	161.2	83.7	15	89	95	127	140	40	40
3/4(20A)	109	104.7	20	161.2	83.7	20	98.5	100	127	150	55	55
1(25A)	109	104.7	20	161.2	83.7	25	108	125	127	150	55	55
1-1/2(40A)	123	136	20	243	108	38	127	140	165	165	73	81
2(50A)	146	136	20	243	108	50	152	155	178	210	95	95
3(80A)	205	148	20	266.2	122.5	76	190.5	185	203	250	125	125
4(100A)	215	189	30	348.5	151	96	229	210	229	280	151	151
6(150A)	281	226	30	449.4	202	145	279.5	280	267	267	212	212

PFA Lined Ball Check Valve

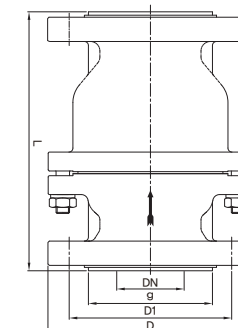

Dimensions

Unit: mm

Size	ANSI	1/2	3/4	1	1 1/2	2	2 1/2	3	4	6	8
	JIS	N/A	20	25	40	50	65	80	100	150	200
d	19	19	25	38	50	64	77	96	145	198	
L	152	152	152	198	192	254	254	317	381	482	
g	51	51	51	81	92	110	125	150	212	264	
Ref	A	B	C	D	E	F	G	H	J	K	



Semiconductor Related Products

Semiconductor Related Products

Tank Lorry & ISO Container

Material
PFA, PTFE, EP



Tank Lorry

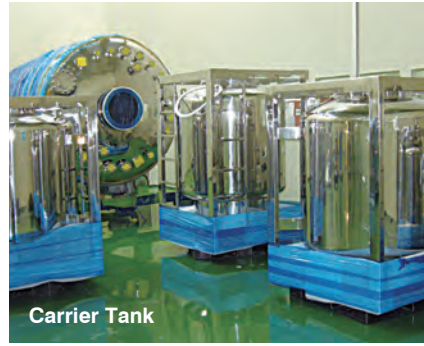

Carrier Tank



ISO Container



ISO Container



EP Drum

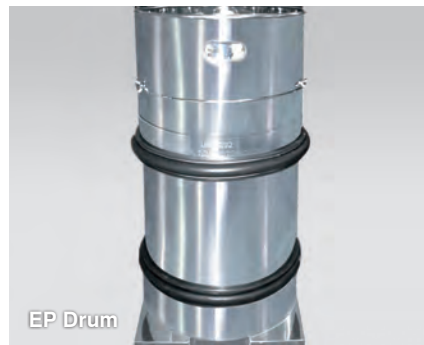

EP Drum

Other Products



Filter Housing

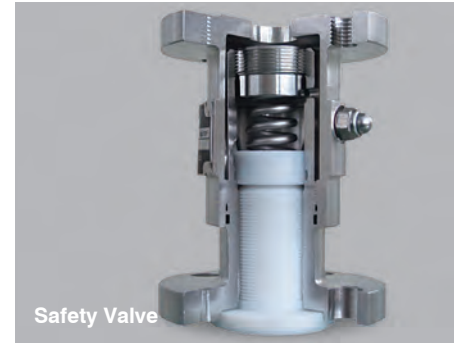

Safety Valve



Gauge



Ball Valve



Valve & Accessory



Diaphragm Valve

Semiconductor Related Products

Plant Engineering & Construction

Other Products



Welding Rod & Ribon



Filter Housing (STARFLON® Lined)

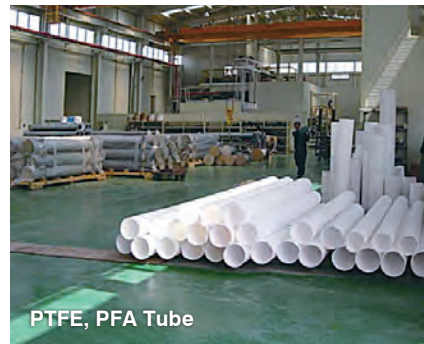

PTFE, PFA Tube



Inspection A/S & Consulting



Inspection A/S & Consulting



DI Cleaning

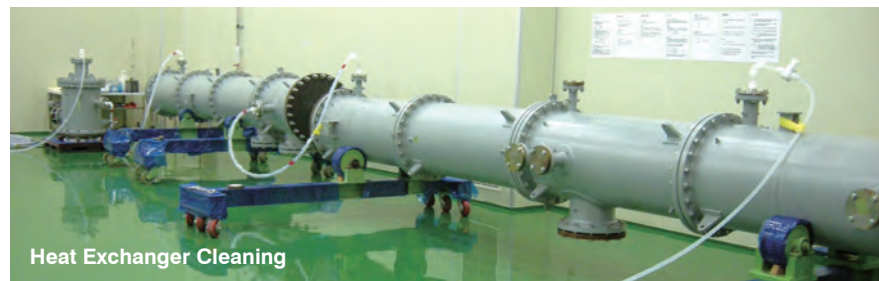

Heat Exchanger Cleaning

Plant Engineering

Today's modern industry exhibits a tendency to precision, specialization and HI-tech. Especially, the advanced technology and its application capability are the most critical essences for the basic industrial field of plant engineering.

Considering the technology as the most important asset of company, Jeil continuously has tried to introduce new materials and technology from advanced countries-U.S.A, Japan, European countries and to meet the requests of customers with highly value-added products.

Through the constant R&D and facilities updating, Jeil will perform a role of international market pioneer and leader with competition power in quality and technology.





Plant Engineering & Construction



Pollution Control Facilities

Plant Construction

Based on the technical know-how and experience meanwhile, Jeil performs the plant construction in the turn-key method from design to installation.
 Jeil's long experience and advanced technology provide innovative and efficient facilities to the related industrial fields of chemicals, semi-conductor, ultra pure chemicals, etc.

Material

- Carbon Steel, SUS
- PTFE, PFA, PVDF, PP, PVC
- FRP, PP+FRP, PVC+FRP



Scrubber, Tank, Piping

Material

- FRP
- PTFE, PFA, PVDF, PP
- Rubber Lining

Nowadays the environmental regulations become more reinforced to meet with the strong demand of the times, "Protection of Only One Earth".
 Jeil has accumulated the efficiently applicable technology of new material and skills for piping construction.
 Jeil designs, fabricates and constructs overall piping facilities including wastewater disposal plant, cleaning tower, etc.

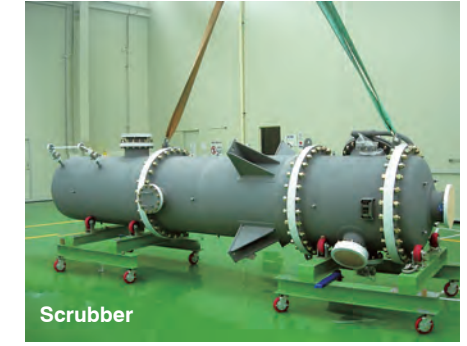

Scrubber

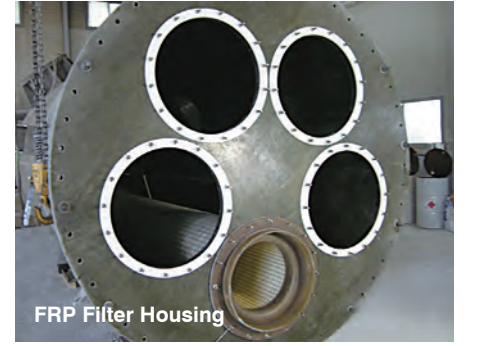

FRP Filter Housing



Rubber Lining



FRP Tank



FRP Piping

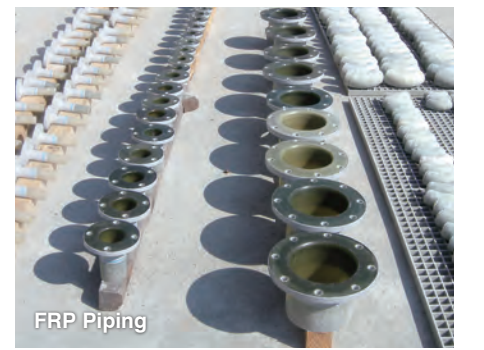

FRP Piping

Pollution Control Facilities

WWT, DI, UPW System

- Clean RO membrane
- Resin regeneration
- Clean CDI modules
- Replace filter media

Environmental pollution including the serious underground water pollution by wastes are not exceptional. Now Jeil is with you to protect against the water pollution from the industrial wastes.



C.P.L (Concrete Protect Lining)

- Material**
- PP + Concrete
 - HD-PE + Concrete
 - FRP + Concrete

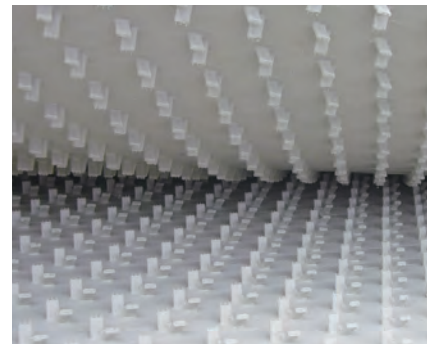

HVAC Products (Heating, Ventilation, Air conditioning)

HVAC Construction



HVAC Products (Heating, Ventilation, Air conditioning)

HVAC Unit



Redial Flow Fan



Side Fan



AHU



Air Washer



Chiller



Gas Oil Plant

Appendix

Comparison between Plastic and Metal

Kind of Material		Specific Gravity	Tensile Strength (kg/mm ²)	Bending Strength (kg/mm ²)	Modulus in Shear (kg/mm ²)	Compressive Strength (kg/mm ²)	Impact Strength (Ft.lb/in)	Thermal Conductivity (Kcal/mh°C)	Liner Expansion Coefficient (10 ⁻⁵ /°C)	Thermal Resistance Temp.(°C)
PTFE(4F)	Polytetrafluoro Ethylene	2.14~2.20	1.4~3.5	-	56	-	3.0	0.22	9.9	260
PFA(0 ~ 4F)	Perfluoroalkoxy Resin	2.12~2.17	2.8~3.0	-	84	-	Not Break	0.22	12	260
FEP(4F ~ 6F)	Fluorinated Ethylene Propylene	2.12~2.17	1.9~2.15	-	56~66	-	Not Break	0.21	8.3~10.5	200
ECTFE(4H ~ 3F)	(HALAR) Ethylene-Tetrafluoroethylene	1.68~1.7	4.2~4.9	-	168	-	Not Break	0.13	8.0	-76~170
ETFE(4H ~ 4F)	(TEFZEL) Ethylene-Tetrafluoroethylene	1.70~1.76	4.1~4.7	3.85	140	3.85	Not Break	0.2	5.9	-50~150
PVdF(2F)	Polyvinylidene Fluoride	1.75~1.78	3.85~5.2	6.05~7.7	140	6.05~7.7	3.8	0.1	7~14	-40~120
PP	Polypropylene	0.91	2.5~3.4	3.40~5.4	110~140	-	0.2~10.9	0.08	15	-20~90
HD-PE	High-Density Polyethylene	0.91~0.93	1.05~1.3	-	-	-	Not Break	0.28	16~20	-40~60
PVC	Polyvinyl Chloride	1.45	3.9~6.3	5.6~10.5	250~420	6.3~7.7	0.5~9.5	0.13	7~8	0~60
FRP MAT(H/L) (30 ~ 40%)		1.4~1.8	7~14	14~28	800~1300	11~18	5~25	0.16~0.23	1.8~3.2	-80~150
FRP(F/W) (60 ~ 90%)		1.7~2.3	56~180	70~190	3500~4900	35~53	40~60	0.24~0.28	0.4~1.1	-80~150
SS400(SS41)		7.85	20~23	19.7	21100	19.7	-	41.5	1.2	350
Stainless Steel		7.93	21~25	21.1~24.6	19700	21.1	8.5~11	14	1.6	650
Hastelloy		8.07	56.1	35.1	18300	-	-	9.7	1.1	600
Aluminum		2.7	4.2~19	14.1	7000	-	-	199.5	2.35	-

* For the special application purpose, please consult with our technical department. the contents of this catalog may change with or without notice.

Chemical Resistance Chart

Chemical Resistance Chart		% Concentration	Approx.SP.Gravity@100%Conc.	Plastic																Elastomer						Seal		Meal				
				PVC	CPVC	Polypropylene(PP)		Polypropylene Fluoride(PVDF)		Polyethylene(PE)		Polyimide(Cross Linked(XLPE))		Duraplus ABS		Halar (ECTFE)-Solvay		Teflon(PTFE)		Epoxy	Vinylester	Polysulfone	Viton	EPDM	Neoprene	Buna N(Nitrile)	Carbon	Ceramic	304 Stainless Steel	316 Stainless Steel	Titanium	Hastelloy C
						°F	°F	°F	°F	°F	°F	°F	°F	°F	°F	°F	°F	°F	°F													
Acetic Acid	CH ₃ COOH	5	-	140	140	200	140	X	140	68	250	350	150	200	-	X	200	100	-	-	-	-	-	-	-	A	A	A	A			
Acetic Acid	CH ₃ COOH	30	-	140	140	200	140	X	140	X	250	350	-	100	-	180	200	-	-	-	-	-	-	-	-	A	A	A	A			
Acetic Acid, Glacial	CH ₃ COOH	100	1	110	110	180	180	X	70	X	212	350	X	X	-	X	73	X	X	A	A	A	A	A	A	A	A	A	A			
Ammonia	NH ₃	25	-	100	X	-	210	-	-	-	210	250	70	140	180	70	-	-	70	A	-	-	-	-	A	A	A	A				
Ammonia	NH ₃	99	-	70	X	-	210	-	-	-	210	250	70	-	-	X	-	-	70	A	-	-	-	-	A	A	A	A				
Ammonia Gas	NH ₃	-	-	100	X	100	100	100	140	X	250	250	140	180	-	X	140	70	100	A	A	A	A	A	A	A	X	-				
Ammonium Hydroxide	NH ₄ OH	20	-	100	X	180	140	100	140	180	250	350	210	140	180	70	180	140	X	A	A	A	A	A	A	A	A	A	A			
Calcium Chloride	CaCl ₂	-	2.1	140	180	180	250	100	140	180	250	350	300	140	180	140	180	140	100	A	NR	B	A	A	A	A	A	A				
Carbon Dioxide (wet or dry)	CO ₂	-	-	140	180	180	250	100	140	180	250	350	180	70	-	210	180	140	140	A	A	A	A	A	A	A	A	A				
Carbon Disulfide	CS ₂	-	-	X	X	X	70	X	X	X	100	350	X	X	X	100	X	X	X	A	A	A	B	A	A	A	A					
Chlorine Gas Dry	Cl ₂	-	-	X	X	X	70	X	X	180	250	X	70	X	100	X	X	X	A	A	A	A	X	A	A	A	A					
Chlorine Gas Wet	-	-	-	X	100	X	210	-	X	X	180	250	X	210	X	X	X	X	X	A	-	X	X	A	A	A	A					
Hydrochloric Acid	HCl	10	-	140	180	180	250	100	140	180	250	250	70	210	180	210	140	140	140	NR	-	B	X	B	B	B	B					
Hydrochloric Acid	HCl	20	-	140	180	180	250	100	140	180	250	250	210	180	180	210	140	140	70	NR	-	X	X	C	B	B						
Hydrochloric Acid	HCl	37	1.19	140	140	140	210	100	140	70	250	250	210	140	180	100	70	X	X	NR	-	X	X	C	B	B						
Hydrocyanic Acid (Prussic Acid)	HCN	-	-	140	140	140	250	100	140	70	250	350	180	180	70	70	70	-	70	A	A	A	A	A	A	A						
Hydrofluoric Acid	HF	5	-	100	140	140	210	100	140	70	250	350	70	140	-	180	100	100	-	NR	-	-	A	X	A	A						
Hydrofluoric Acid	HF	20	-	70	140	140	210	100	140	70	250	350	70	140	-	180	100	100	-	NR	-	X	A	X	A	A						
Hydrofluoric Acid	HF	40	-	70	100	140	210	100	140	70	250	350	X	140	X	180	100	100	X	NR	-	X	X	X	A	A						
Hydrofluoric Acid	HF	50	-	70	X	140	250	140	140	X	250	350	X	X	X	180	100	100	X	NR	-	X	X	X	A	A						
Hydrogen Peroxide	H ₂ O ₂	10	-	140	140	70	210	100	100	70	250	350	140	140	100	180	100	X	X	A	A	B	B	A	A	A						
Hydrogen Peroxide	H ₂ O ₂	30	-	100	70	70	210	100	100	-	250	350	140	140	100	100	70	X	X	A	A	B	B	A	A	A						
Hydrogen Peroxide	H ₂ O ₂	90	-	X	X	X	-	100	-	X	140	350	X	-	100	100	-	X	X	A	A	A	A	A	A	A						
Nitric Acid	HNO ₃	10	-	140	180	140	250	100	140	70	250	350	X	180	70	180	100	X	X	A	A	B	A	A	A	A						
Nitric Acid	HNO ₃	30	-	100	140	100	210	100	140	-	250	350	X	100	70	140	-	X	X	A	A	C	A	A	A	A						
Nitric Acid	HNO ₃	70	-	X	70	X	100	-	X	X	140	350	X	X	X	X	X	X	X	A	A	B	C	A	A	A						
Sodium Hydroxide	NaOH	15	-	140	140	140	140	100	140	180	250	350	210	180	180	X	180	140	180	NR	NR	X	A	A	A	A						
Sodium Hydroxide	NaOH	30	-	140	140	140	140	100	140	70	250	350	210	180	210	X	180	140	180	NR	NR	X	A	A	A	A						
Sodium Hydroxide	NaOH	70	-	140	140	100	X	100	140	70	140	350	-	-	-	X	70	70	X	NR	NR	A	A	C	A							
Sulfuric Acid	H ₂ SO ₄	10	-	140	180	180	X	100	70	180	210	350	100	210	250	250	180	140	140	-	-	X	X	A	B	B						
Sulfuric Acid	H ₂ SO ₄	50	-	140	180	140	250	100	70	70	210	350	210	210	180	210	140	140	70	-	-	X	X	C	A	A						
Sulfuric Acid	H ₂ SO ₄	90	-	70	70	70	210	100	X	X	210	350	X	X	-	140	100	X	X	-	-	X	A	X	A	A						

* This table is for reference only. For more information, please contact sales department.

Gasket & Packing

Non-Metallic Sheets & Gaskets

Compressed Non-Asbestos Sheets & Gaskets

A. Industrial Applications		
Aramid Fiber + NBR	JIC 6000	
Aramid Fiber + NBR + Wire Reinforced	JIC 6000W	
Aramid Fiber + NBR	JIC 6010	
Organic Fiber + NBR	JIC 6030	
Aramid Fiber + SBR	JIC 6100	
Aramid Fiber + NBR	JIC 6200	
Carbon Fiber + NBR	JIC 6400	
Carbon Fiber + NBR + Wire Reinforced	JIC 6400W	

B. Automotive Applications

Aramid Fiber + Synthetic Rubber	JIC 6210	
Aramid Fiber + NBR	JIC 6215	
Aramid Fiber + Synthetic Rubber	JIC 6330	
Aramid Fiber + NBR	JIC 6700	

STARFOIL® Sheets & Gaskets

STARFOIL® (Flexible Graphite) Sheets & Gaskets	JIC 4201Series	
Pure Graphite Sheet	JIC 4201	
Stainless Steel Flat Reinforced Graphite Sheet	JIC 4201-P	
Stainless Steel Tanged Reinforced Graphite Sheet	JIC 4201-B	
Stainless Steel Wire-Mesh Reinforced Graphite Sheet	JIC 4201-W	
STARFOIL® Plain Tape	JIC 4204	
STARFOIL® Crinkled Tape	JIC 4205	

STARFLON® Sheets & Gaskets

STARFLON® (PTFE) Solid Gasket	JIC 8305	
STARFLON® (PTFE) Reinforced Gasket	JIC 8305G	
STARFLON® (PTFE) Enveloped Gasket	JIC 8310	
STARFLON® (PTFE) Jacketed Gasket	JIC 8313	
STARFLON® (PTFE) Expanded Sheet Gasket	JIC 8312	
STARFLON® (PTFE) Joint Sealant Gasket	JIC 6066	

STARPITE® Sheets & Gaskets

Stainless Steel Reinforced STARPITE® Sheet (For High Temperature)	JIC 4201-HT	
---	-------------	--

Semi-Metallic Gaskets

Spiral Wound Gaskets

STARFOIL® (Flexible Graphite) Filled Type	JIC 38□□-SF Series	
Non-Asbestos Filled Type	JIC 38□□-NA Series	
STARFLON® (PTFE) Filled Type	JIC 38□□-TF Series	

High Temperature Spiral Wound Gaskets

Multi-Filler Filled Type	JIC 380□-Multi-Filler	
	JIC 380□-R-Multi-Filler	
	JIC 383□-Multi-Filler	
	JIC 383□-R-Multi-Filler	
STARPITE® Filled Type	JIC 380□-HT	
	JIC 380□-R-HT	
	JIC 383□-HT	
	JIC 383□-R-HT	
Multi-Filler Filled Type(HTG)	JIC 380□-HTG	
	JIC 380□-R-HTG	
	JIC 383□-HTG	
	JIC 383□-R-HTG	

Metal Jacketed Gaskets

Non-Asbestos Filled (NA) Filler	JIC 38□□-NA Series	
Ceramic (CE) Filler	JIC 38□□-CE Series	
STARFOIL® (SF) Filler	JIC 38□□-SF Series	
STARFOIL® Tape Attached	JIC 38□□-SF(SF) Series	

Kammprofile Gaskets

Parallel Root	JIC 3850-SE(SF)	
Floating Centering Ring	JIC 3850-SEB(SF)	
Convex Root	JIC 3850-SEC(SF)	

Gland Packing

Expanded Graphite Packing	JIC 3020
Inconel Wire Inserted Expanded Graphite Packing	JIC 3020-I
PTFE Fiber Packing	JIC 3063
Lubricated PTFE Fiber Packing	JIC 3064
Lubricated PTFE Fiber and Aramid Fiber Packing	JIC 3065
Lubricated PTFE Fiber and Graphite Fiber Packing	JIC 3067
PTFE / Graphite Fiber Packing	JIC 3076
PTFE Fiber Packing	JIC 3076-W
Hatch Cover Packing	JIC 3069
	JIC 3069-GS
Inconel Wire Inserted Carbon Fiber Packing	JIC 3072
PTFE Impregnated Carbon Fiber Packing	JIC 3074
Lubricated Carbon Fiber Packing	JIC 3074-CR
Lubricated PTFE Impregnated Carbon Fiber Packing	JIC 3075
PTFE Impregnated Carbonized Fiber Packing	JIC 3094
Lubricated PTFE Impregnated Carbonized Fiber Packing	JIC 3095
PTFE / Graphite Fiber and Aramid Fiber Packing	JIC 3077
Lubricated PTFE Impregnated Aramid Fiber Packing	JIC 3080
Inconel Wire Inserted Glass Fiber Packing	JIC 3085
STARFOIL® Molded Packing	JIC 4101
Anti - VOC Packing Set	JIC 4101-VOC

Rubber Sheets & Gaskets

Natural Rubber Sheets & Gaskets (NR Rubber)	JIC 9000(9001)-NR
Nitrile Butadiene Rubber Sheets & Gaskets (NBR Rubber)	JIC 9000(9001)-NBR
Chloroprene Rubber Sheets & Gaskets (Neoprene Rubber)	JIC 9000(9001)-CR
EPDM Rubber Sheets & Gaskets	JIC 9000(9001)-EPDM
Silicon Rubber Sheets & Gaskets	JIC 9000(9001)-SL
Styrene Butadiene Rubber Sheets & Gaskets (SBR Rubber)	JIC 9000(9001)-SBR
Fluoro Elastomer Sheets & Gaskets (VITON Rubber)	JIC 9000(9001)-FKM
Isobutylene-Isoprene Rubber Sheets & Gaskets (Butyl Rubber)	JIC 9000(9001)-IIR
STARFLON® / EPDM Rubber Gaskets	JIC 9010-EPDM

Insulation Sets

RF Type	JIC 7700-R
FF Type	JIC 7700-F
RTJ Type	JIC 7700-RJ
STARFLON® (PTFE) Solid Gasket	JIC 8305
STARFLON® (PTFE) Reinforced Gasket	JIC 8305G
CR Rubber Faced Phenolic Gasket	JIC 9020-CP
STARTEC® Gasket	
Glass Reinforced Epoxy Plate Gasket With Rubber Seal	JIC 9210-ER
Glass Reinforced Phenolic Plate Gasket With Rubber Seal	JIC 9220-PR
Glass Reinforced Epoxy Plate Gasket With Rubber O-Ring	JIC 9230-ES